

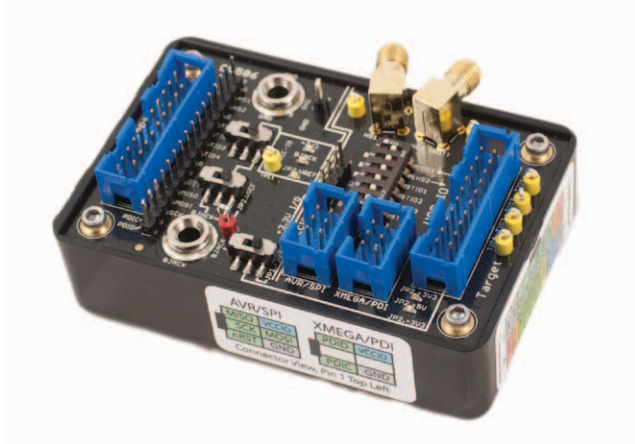

CW506 Advanced Breakout



The CW506 advanced breakout board can be used with both our Capture hardware and our Targets, either together or stand-alone.

Use with the capture devices to provide level shifting for interfacing from 1.5V to 5.0V device I/O. Also provides handy breakouts for connecting other equipment (such as logic analyzers and oscilloscopes) to data or clock lines.

Use with targets to interface standard lab gear such as USB-LVTTTL adapters and FPGA boards to our targets.

Product Highlights

3.3V I/O for ChipWhisperer Capture.

1.5-5.0V I/O for Target Devices.

Very high-speed clock translators for clock or fault waveform voltage translations.

I/O translators allow usage of UART,SPI, JTAG, and similar protocols.

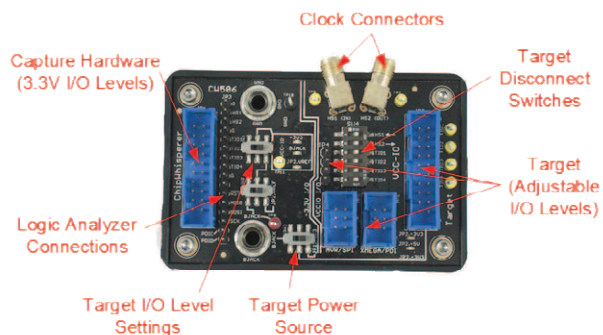
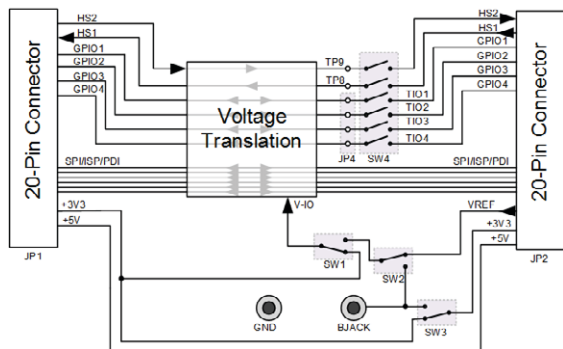

Ordering Summary

NAE-CW506 Advanced breakout board with one 20-pin cable.

Product Links

Full Documentation https://wiki.newae.com/CW506_Advanced_Breakout_Board

Schematic

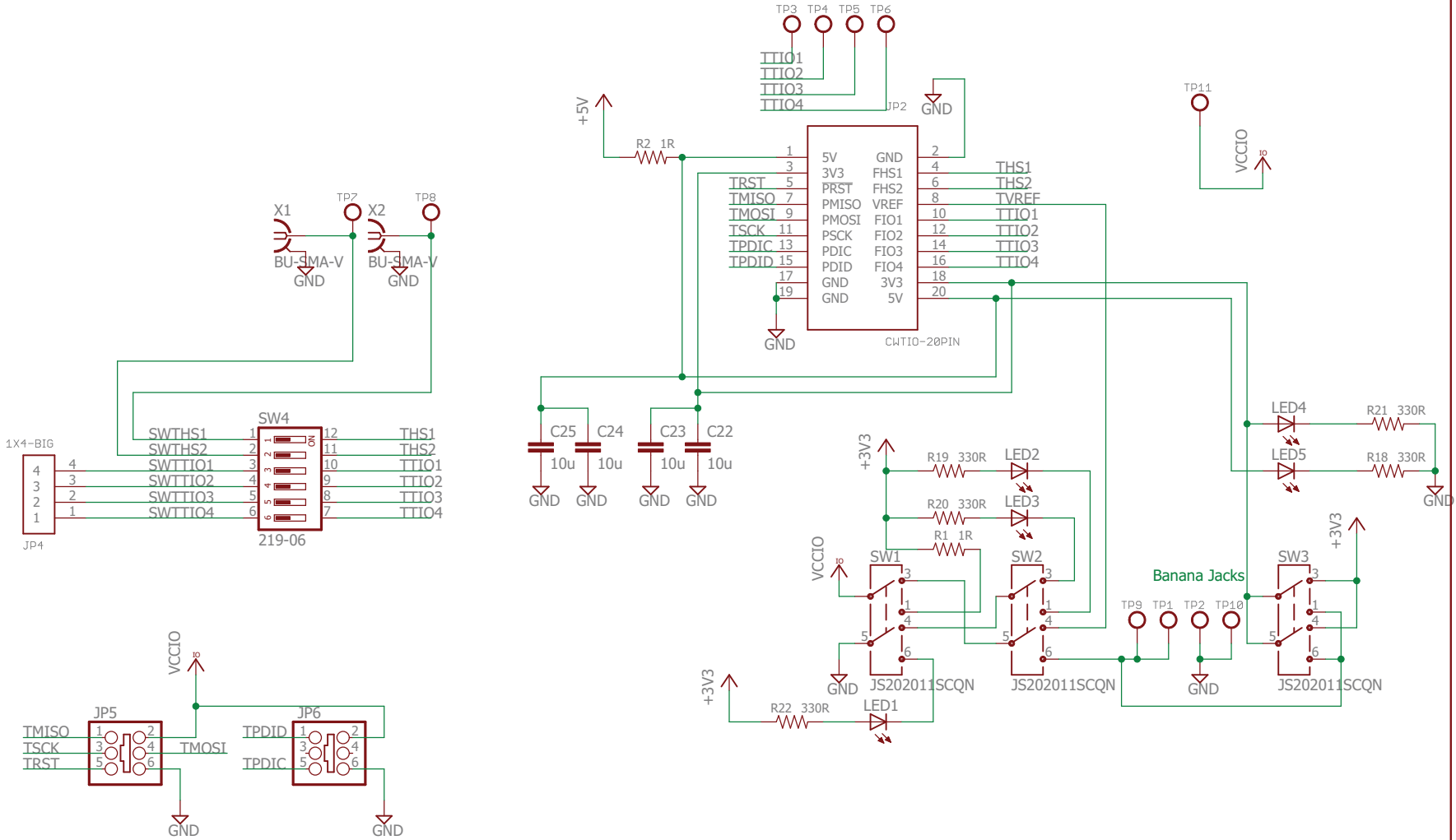

<h2>CW506 Advanced Breakout</h2>	
TITLE: cw506_advbreak	
Document Number:	REV:
Date: 06/06/2016 11:45 PM	Sheet: 1/2

Schematic

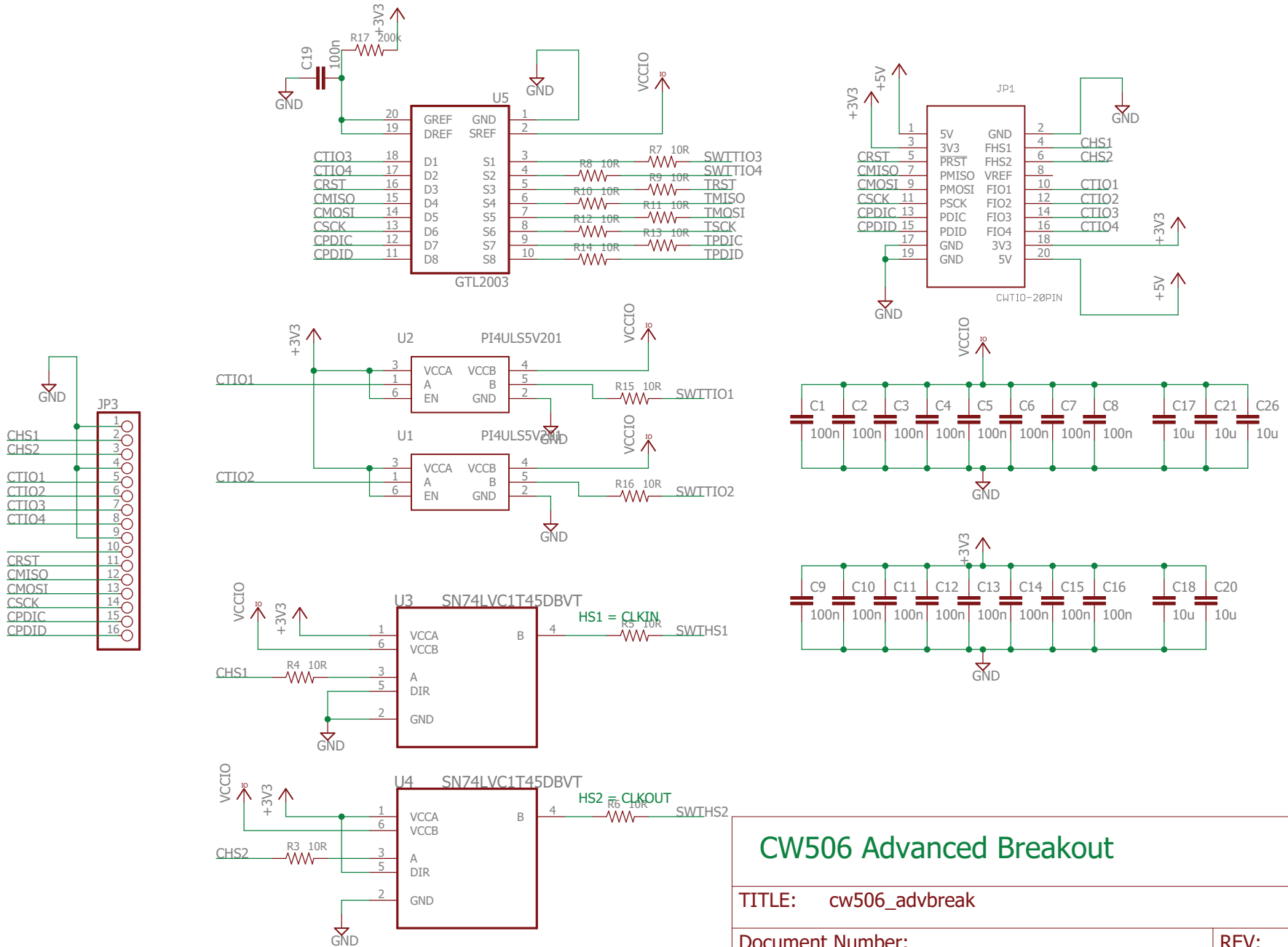

CW506 Advanced Breakout

TITLE: cw506_advbreak	
Document Number:	REV:
Date: 06/06/2016 11:45 PM	Sheet: 2/2

Disclaimers

All content is Copyright NewAE Technology Inc., 2018. ChipWhisperer is a trademark of NewAE Technology Inc., registered in the United States of America and Europe. ChipSHOUTER is a trademark of NewAE Technology Inc., registered in Europe. Trademarks are claimed in all jurisdictions and may be registered in other states than specified here.

NewAE Technology makes no representations or warranties with respect to the accuracy or completeness of the contents of this document and reserves the right to make changes to specifications and product descriptions at any time without notice. NewAE Technology does not make any commitment to update the information contained herein. NewAE Technology products are not intended, authorized, or warranted for use as components in applications intended to support or sustain life. NewAE Technology products are designed solely for teaching purposes.

All other product names and trademarks are the property of their respective owners, which are in no way associated or affiliated with NewAE Technology Inc. Use of these names does not imply any co-operation or endorsement.