

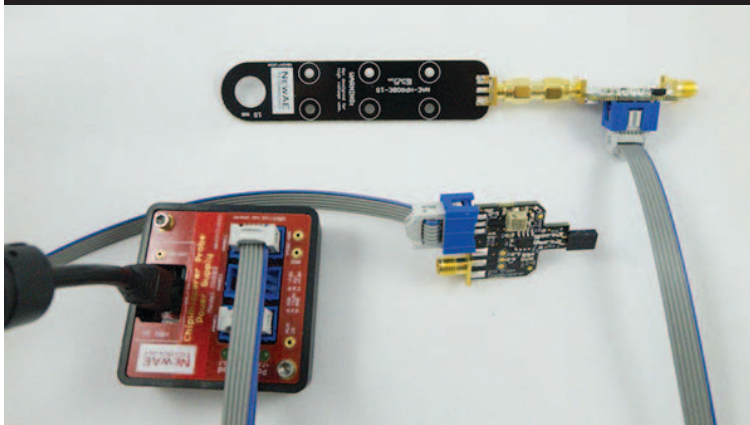

NewAE Technology Inc.
newae.com

Probe Set with Power Supply



A combination of our H-Field probe, Low Noise Amplifier, Differential Probe, and power supply makes for a handy kit for interfacing with various measurement devices.

Power Supply provides $\pm 7.8V$ for differential probe and $+3.3V$ for Low Noise Amplifier. Power supply is isolated to break ground loops that may be present if powering probe from oscilloscope front-panel USB socket.

Product Highlights - Differential Probe

- Usable over 20 kHz - 200 MHz.
- Can be used down to DC with jumper change.
- 10x gain.
- Adjustable DC-offset null.
- LED feedback for null voltage setting.
- Based on AD8129 Differential Amplifier.
- Usable on both VCC and GND shunts.
- Can operate on VCC shunt with single-ended power supply, requires dual-ended supply for GND shunts.

Product Highlights - Low Noise Amplifier

- LNA provides 20dB of gain.
- Physical small size can be easily integrated close to measurement source to reduce noise.

Product Highlights - H-Field Probe

- Super-simple design means a low-cost H-Field probe.
- Can mount the LNA directly onto the probe to minimize noise introduced in cable.
- Can be used for injecting EM faults in addition to measurement applications.

Product Highlights - Probe Power Supply

- Micro-USB input allows wide range of power sources, including front-panel USB connection available on most recent test equipment.
- Isolated design to break ground loops.
- Provides $\pm 7.8V$ for differential probe and $+3.3V$ for Low Noise Amplifier.

Ordering Summary

NAE-PBSET-PSU Probe set with power supply.

Product Links

Full Documentation https://wiki.newae.com/CW501_Differential_Probe
https://wiki.newae.com/CW502_Low_Noise_Amplifier
https://wiki.newae.com/CW503_Probe_Power_Supply
https://wiki.newae.com/CW505_Planar_H-Field_Probe

Differential Probe Usage

The probe is typically used across a shunt resistor. The differential aspect is required to reject noise from the device power supply unrelated to the dynamic power consumption of the device under test.

This is especially useful when a shunt resistor is inserted into a real system, such as lifting a power pin of a TQFP device and inserting a shunt.

The probe also fits on most ChipWhisperer measurement targets including the CW305 and CW308. Note these targets already have a low-noise power supply and do not normally benefit from the differential probe, but instead the probe connection is provided to help understand the effect of the differential probe compared to single-ended probes in various noise environments.

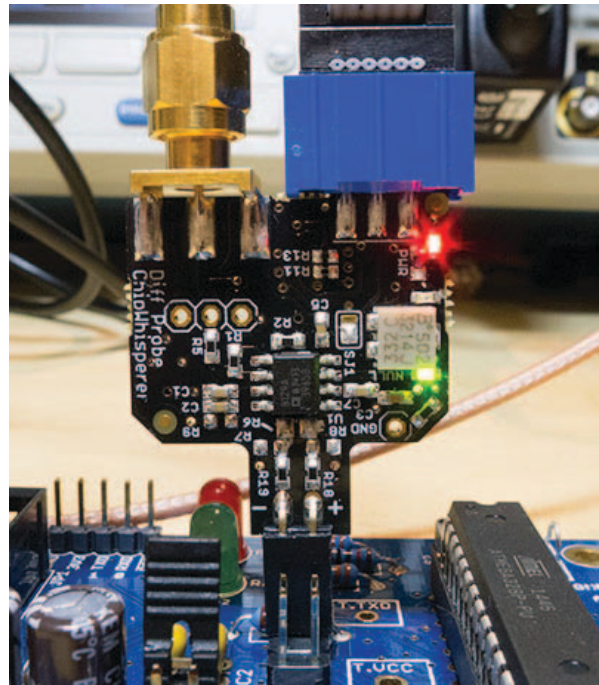

Differential Probe Power - General Notes

The supply voltages of the differential probe must be at least 2V above/below (for +V & -V respectively) the common mode voltage. The Probe Power Supply (CW503) provides a +/- 8V supply, allowing you to use the probe on any reasonable shunt inserted into VCC and GND.

If not using the CW503 probe power supply, ensure voltages are sufficient for your use. For example:

- If measuring the power across a shunt in the 3.3V rail, you should power the probe with at least +5V on the positive rail.
- If measuring the power across a shunt in the GND rail, you should power the probe with at least -2.25V on the negative rail, and +2.25V on the positive rail (the device requires 4.5V minimum between rails).

Be aware that if powering the probe via a single-ended supply (see below), you can only use the probe on a VCC shunt. The following shows the pinout of the 6-pin connector:

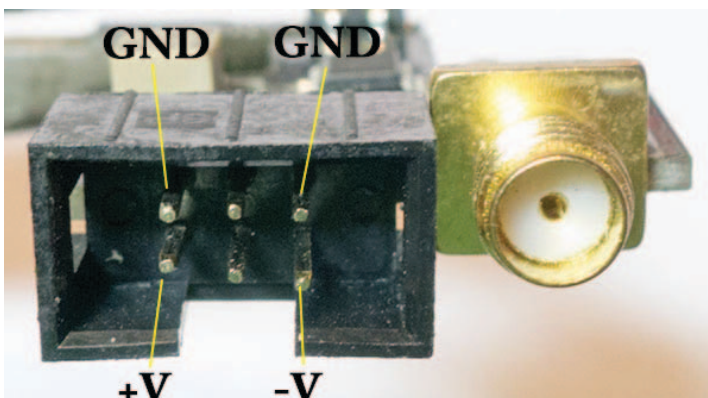

Differential Probe Power - Single Ended

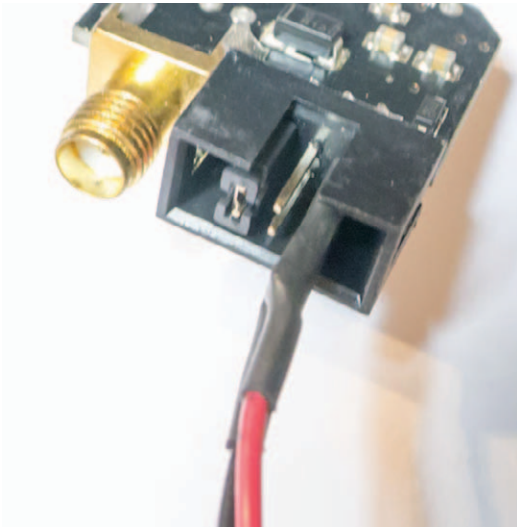

Using a single-ended supply means connecting the -V input to the GND pad. This is done via a jumper mounted as shown on the 6-pin connector on left.

Note again the common-mode limits still apply. This means the common-mode voltage must be at least +2V since the -V supply is 0V. Thus you can only use the single-ended power supply for a VCC shunt.

Differential Probe Schematic

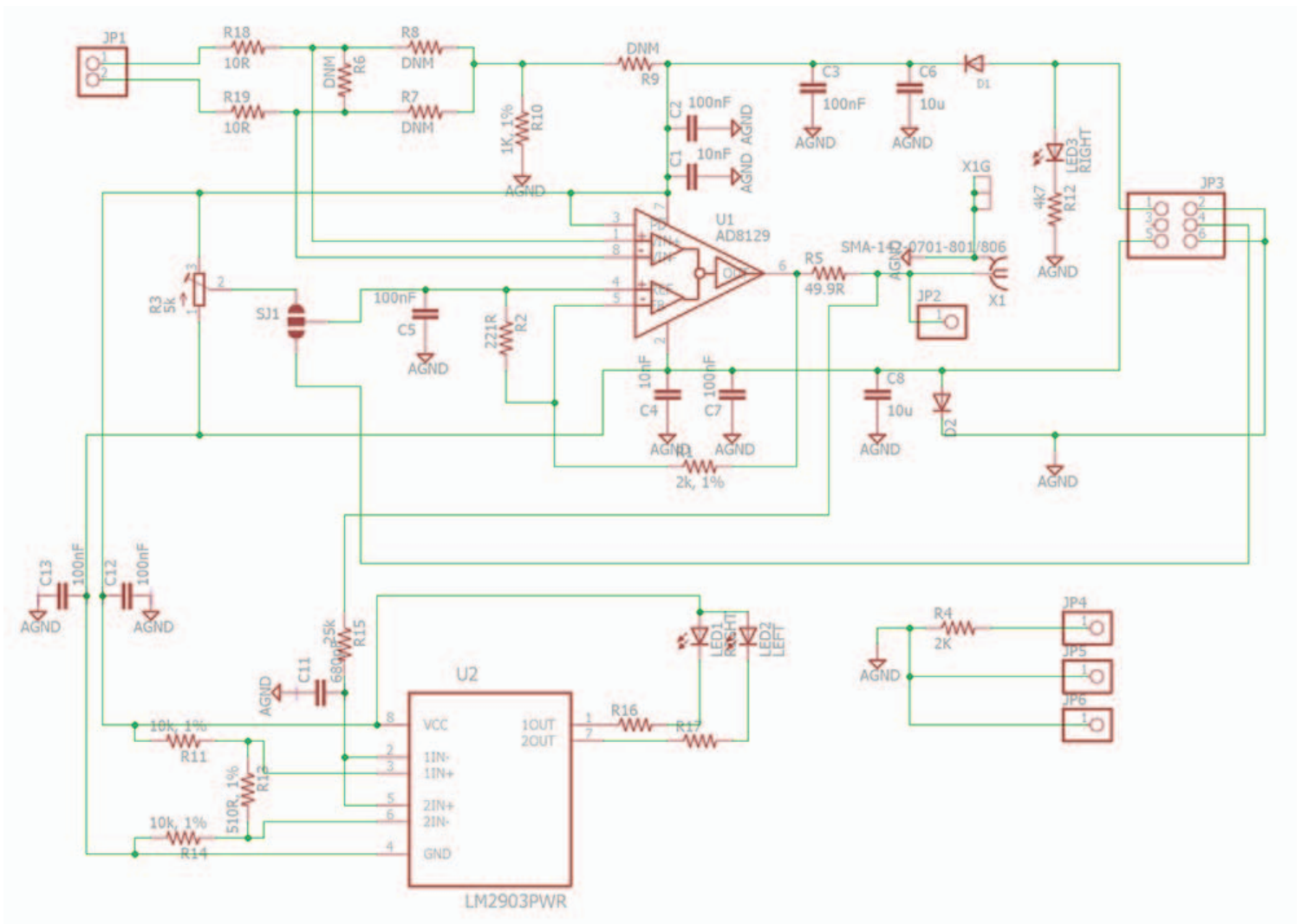

Input Options

Note there are a variety of additional input options. In particular R6 can be used as a shunt resistor if you wish to keep the measurement shunt on the probe itself.

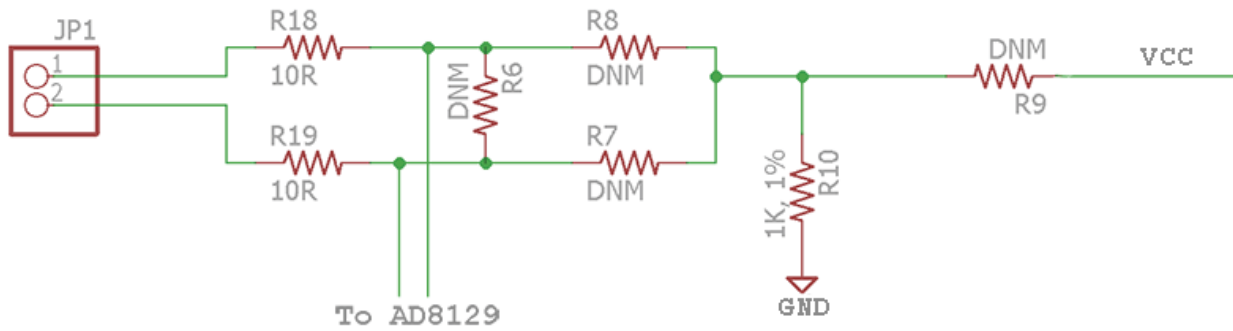

Differential Probe Typical Bandwidth

DG85AQ Vector Network Analyzer Software
 22/10/2013 3:22:51 PM S21 ChipWhisperer Differential Probe

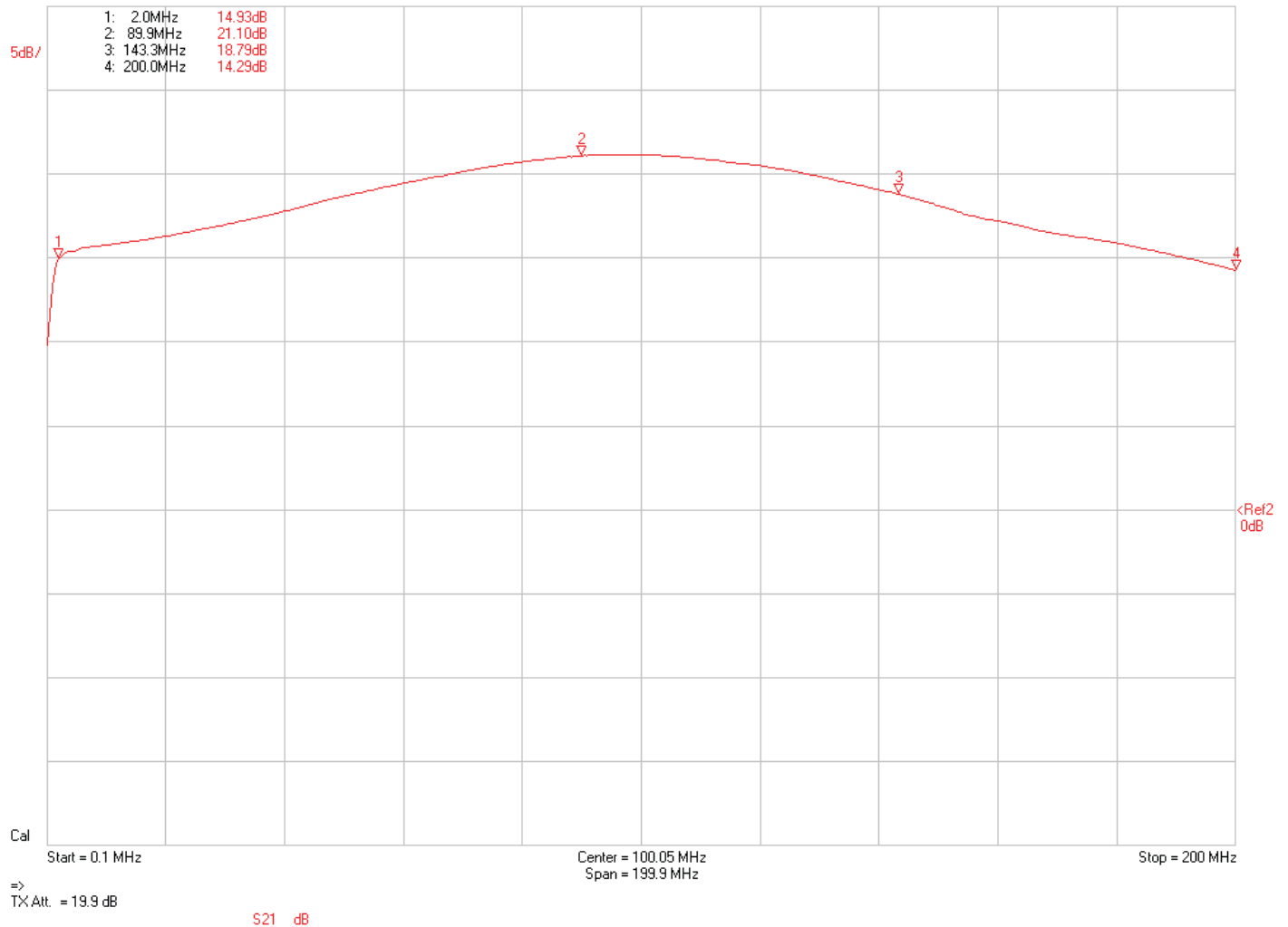

LNA Usage

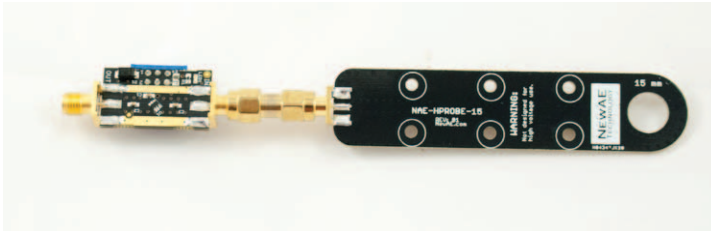

The LNA can be mounted directly onto the H-Field probe. Be sure to power the LNA using the 6-pin cable & note the H-Field probe connects to the INPUT side of the LNA.

Recommended when using the H-Field probe.

LNA Typical Bandwidth

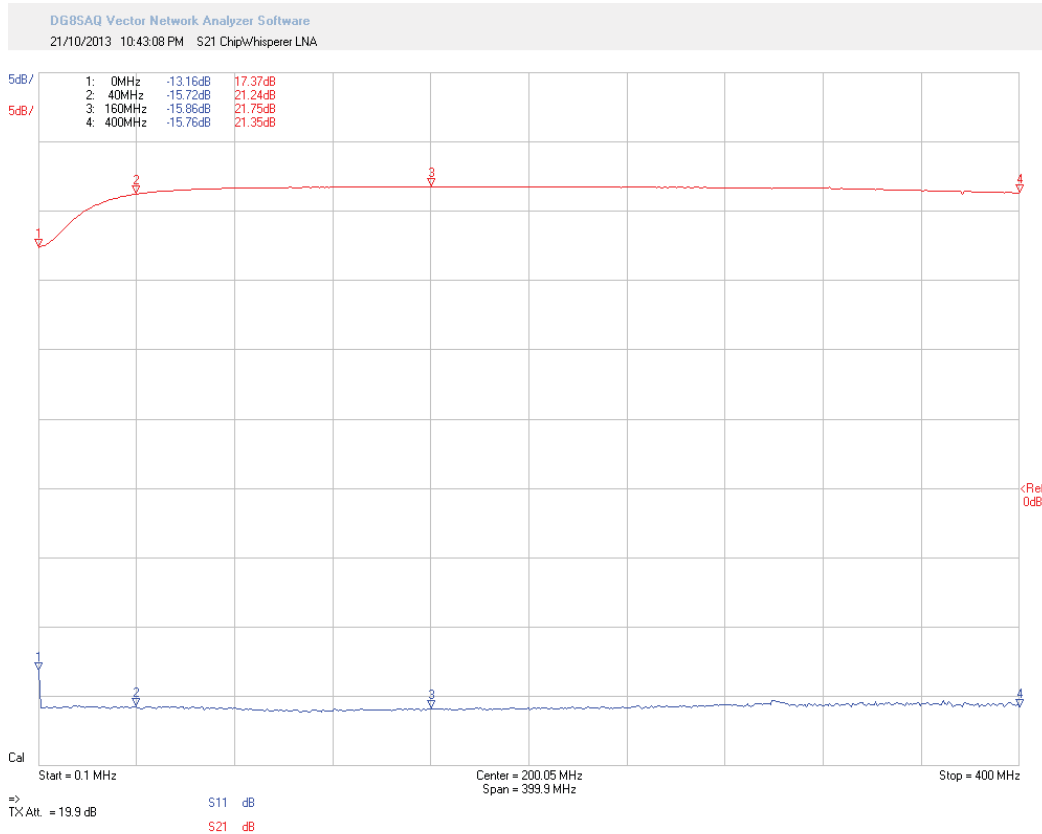

H-Field Probe Construction Overview

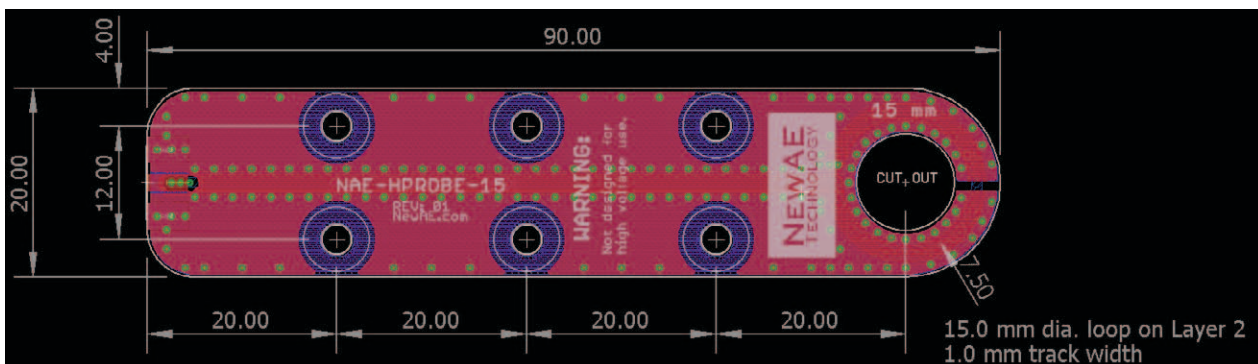

The above shows all four layers of the PCB used in the planar H-Field probe. The specific layers are shown on the following page.

H-Field Probe Construction Details

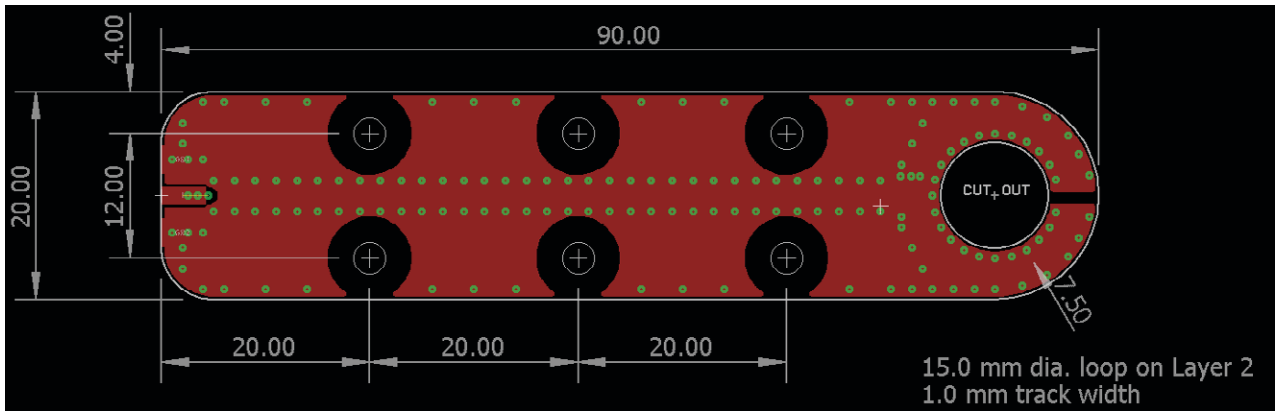

L1

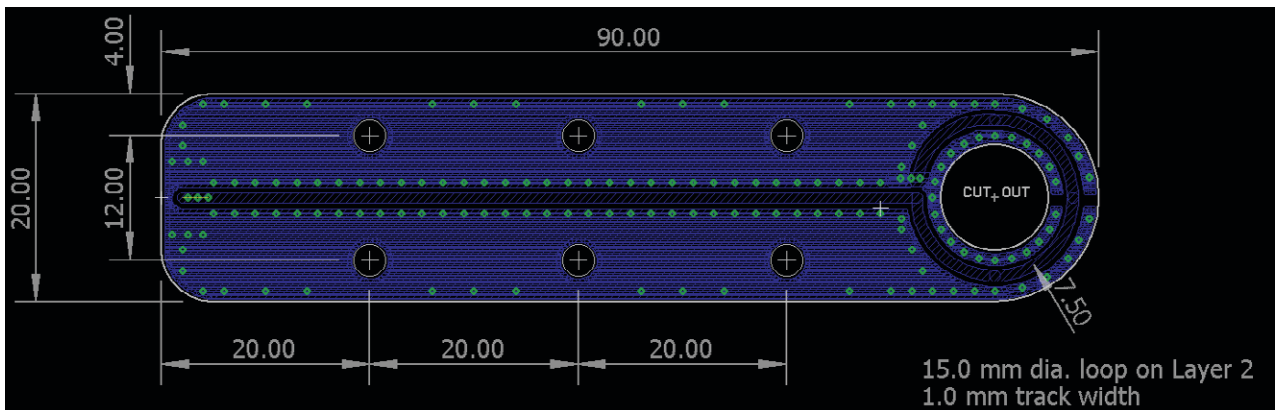

L2

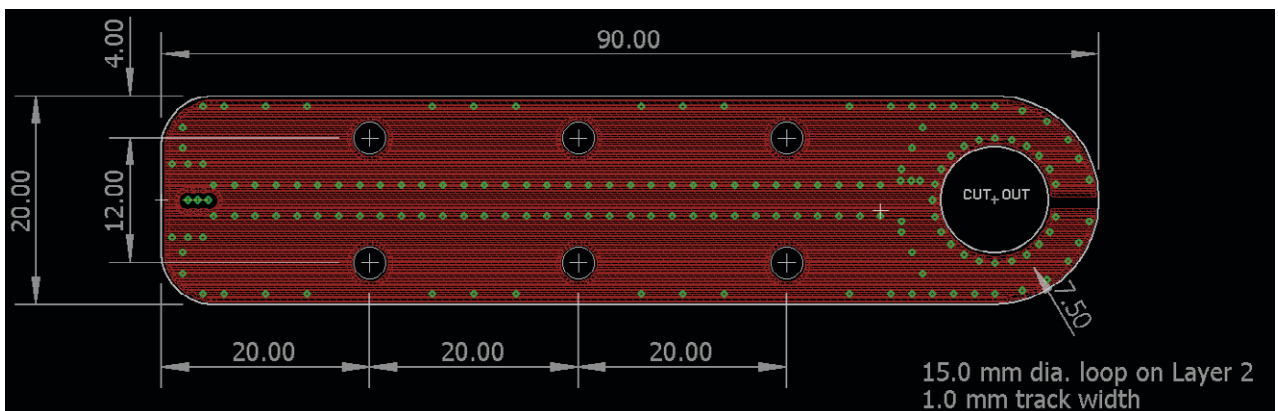

L3

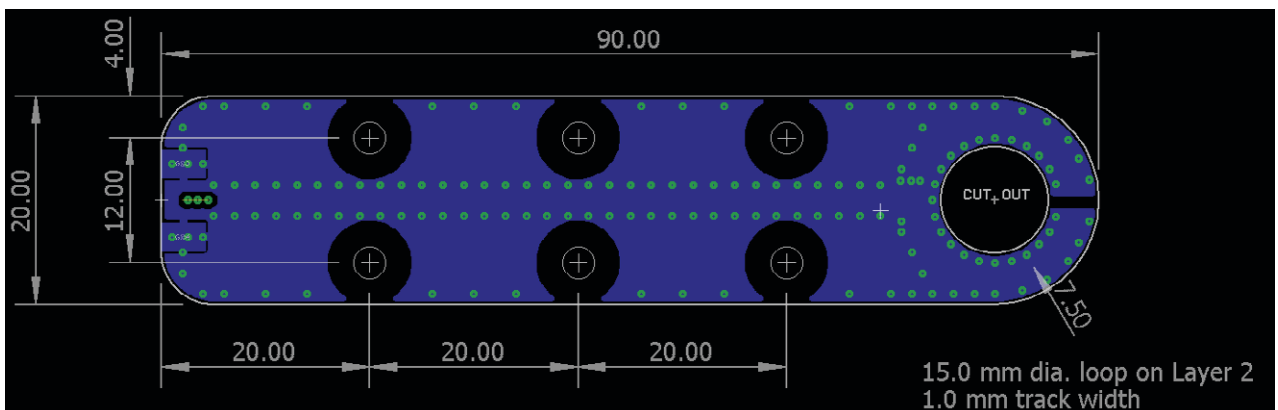

L4

Probe Power Supply (PSU) Details



The probe power supply is designed to provide power to the differential probe and low noise amplifier.

It outputs the needed voltages to use the differential probe in both high and low-side shunt measurements up to 5.0V.

The input source is a 5.0V DC power provided by the micro-USB connector. Note the power is isolated from this using DC-DC converters to avoid potential ground loops.

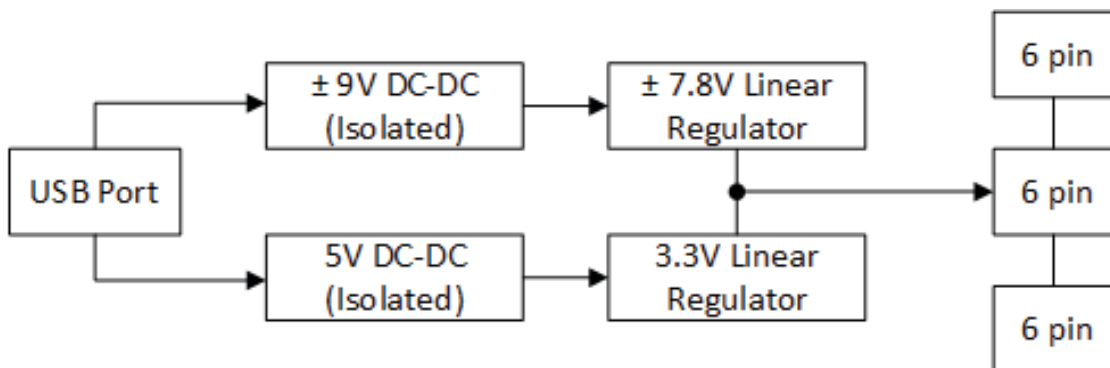

Disclaimers

All content is Copyright NewAE Technology Inc., 2018. ChipWhisperer is a trademark of NewAE Technology Inc., registered in the United States of America and Europe. ChipSHOUTER is a trademark of NewAE Technology Inc., registered in Europe. Trademarks are claimed in all jurisdictions and may be registered in other states than specified here.

NewAE Technology makes no representations or warranties with respect to the accuracy or completeness of the contents of this document and reserves the right to make changes to specifications and product descriptions at any time without notice. NewAE Technology does not make any commitment to update the information contained herein. NewAE Technology products are not intended, authorized, or warranted for use as components in applications intended to support or sustain life. NewAE Technology products are designed solely for teaching purposes.

All other product names and trademarks are the property of their respective owners, which are in no way associated or affiliated with NewAE Technology Inc. Use of these names does not imply any co-operation or endorsement.